

DC/DC Converter (M24B9M300B)

1 Features

- Input DC Voltage range: 18~36V
- Typical input DC voltage: 24V
- Output voltage: 9V
- Output power:300W
- Working Temperature (T_c) :-55~100℃
- Lead function: Pin-pin replacement with similar product of Vicor

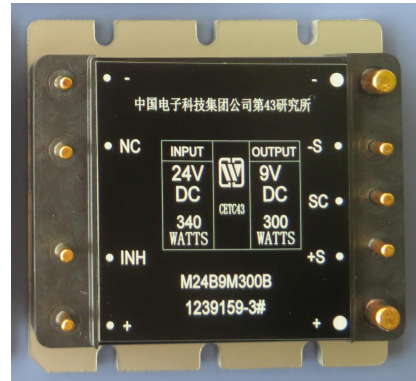

58.28×56.15×13.50mm³
Weight: ≤110g

Fig 1 Product type

2 Scope of application

M24B9M300B

M24B9M300B DC/DC Converter is used in aerospace high reliable electronic system.

3 Descriptions

M24B9M300B DC/DC Converter is used by forward circuit topological structure, and combined with technology for active clamp, have the features such as high efficiency, small ripple, stable performance, convenient assembly and so on. The interior use all the potting, improve heat dissipation effect and reliability of the product.

4 Technical Specifications

Unless otherwise specified, the electrical characteristics shall be in accordance with Table2 and shall apply to the full operating temperature range.

Form 2 Rated condition and recommended condition

Absolute max rating	Recommended condition
Input voltage: 40V Output power: 300W Storage temperature: -65~105℃ Leads resistance welding temperature (10s) : < 300℃	Input voltage: 18~36V Working temperature range (T _c) : -55~100℃

Shell temperature: $\leq 100^{\circ}\text{C}$

Form 3 Electrical Characteristic

No.	Characteristic	Conditions (otherwise specified, $-55^{\circ}\text{C} \leq T_c \leq 125^{\circ}\text{C}$, $V_{IN} = 24\text{V} \pm 1.2\text{V}$)	M24B9M250B		Unit	
			min	max		
1	Output voltage V_{out}	$T_c = 25^{\circ}\text{C}$, full load	8.8	9.2	V	
2	Output current I_{out}	$T_c = 25^{\circ}\text{C}$, full load	0	33.33	A	
3	Voltage regulation rate $\% S_v$	18 36V, full load	-	2	%	
4	Load regulation rate $\% S_I$	Empty load, full load	-	2	%	
5	Temperature coefficient $\% \Delta v$		-0.02	0.02	$\% / ^{\circ}\text{C}$	
6	Efficiency $\% \eta$	full load	$T_c = 25^{\circ}\text{C}$	88	-	%
			$T_c = -55^{\circ}\text{C}$	85	-	%
			$T_c = 100^{\circ}\text{C}$			
7	Electrical level inhibition $V_{inhibit}$	$T_c = 25^{\circ}\text{C}$, $I_{out} = 1\text{A}$, No voltage, output inhibition	-	0.2	V	
8	Insulation resistance R_{iso}	$T_c = 25^{\circ}\text{C}$, between two of input, output, bottom plate is 500V(DC)	10	-	$\text{M}\Omega$	
9	Output ripple voltage(peak-peak) V_R	$T_A = 25^{\circ}\text{C}$, $\text{BW} \leq 20\text{MHz}$, full load	-	200	mV	
10	Short-circuit protection	$T_A = 25^{\circ}\text{C}$, output short circuit	-	2	S	

5 Circuit block diagram

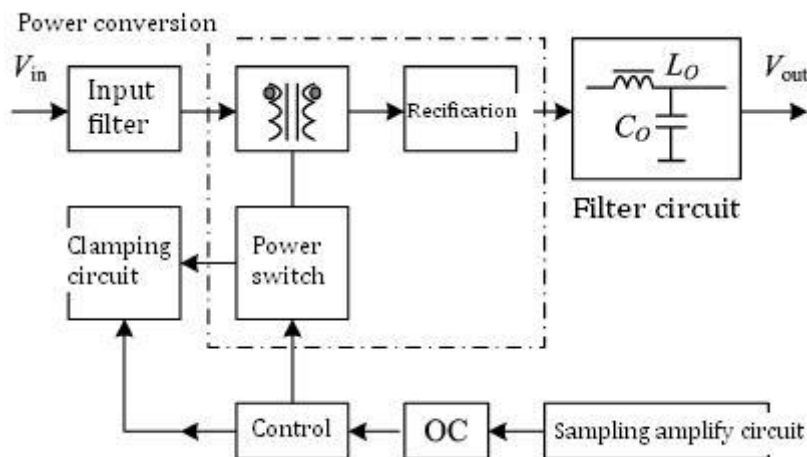

Fig 2 Product elementary diagram

6. Typical characteristic curve

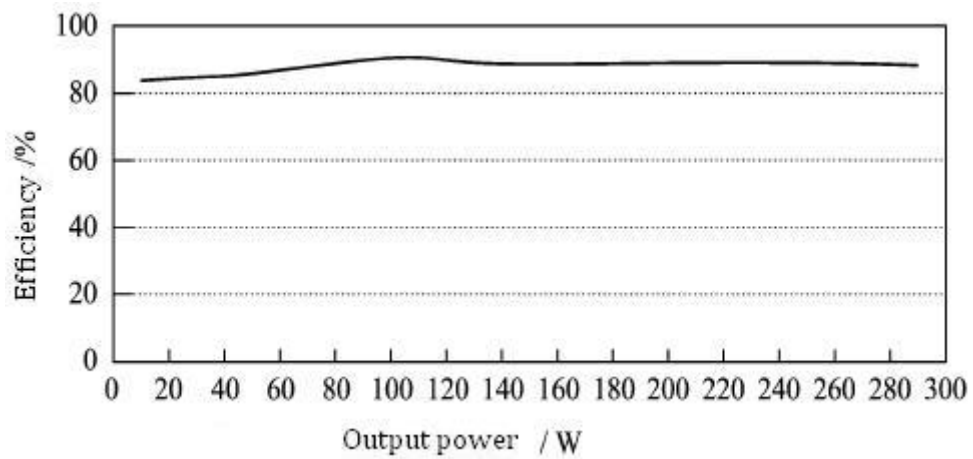
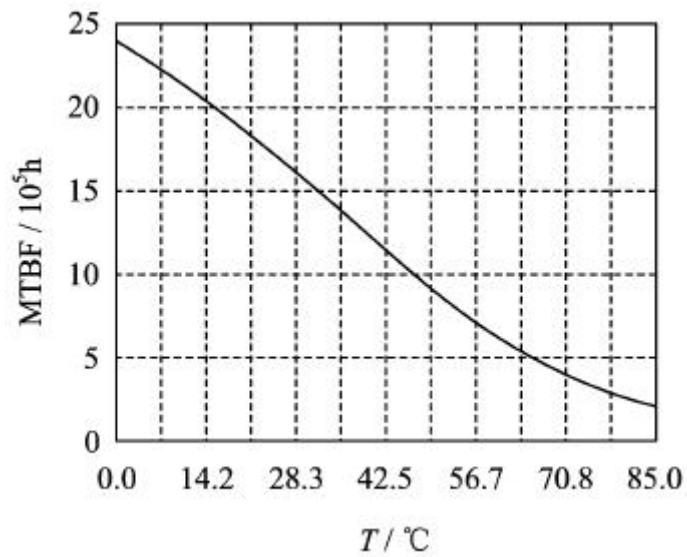

Fig 3 Efficiency (output power)

7.MTBF curve



Char 4 MTBF Temperature Curve

(Prediction is based on well grounded)

8 Pin Designation

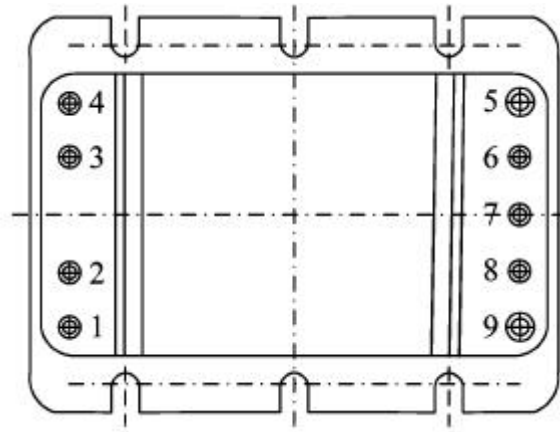

Fig 5 Upward view

Form 4 Pin Designation

No.	Symbol	Function
1	+In	Input positive terminal
2	INH	Inhibition terminal
3	NC	Empty terminal
4	-	Input negative terminal
5	- Out	Input negative terminal
6	- S	Negative induction terminal
7	SC	Secondary-side control terminal
8	+ S	Positive induction terminal
9	+	Output positive terminal

9 Typical Connection Diagram

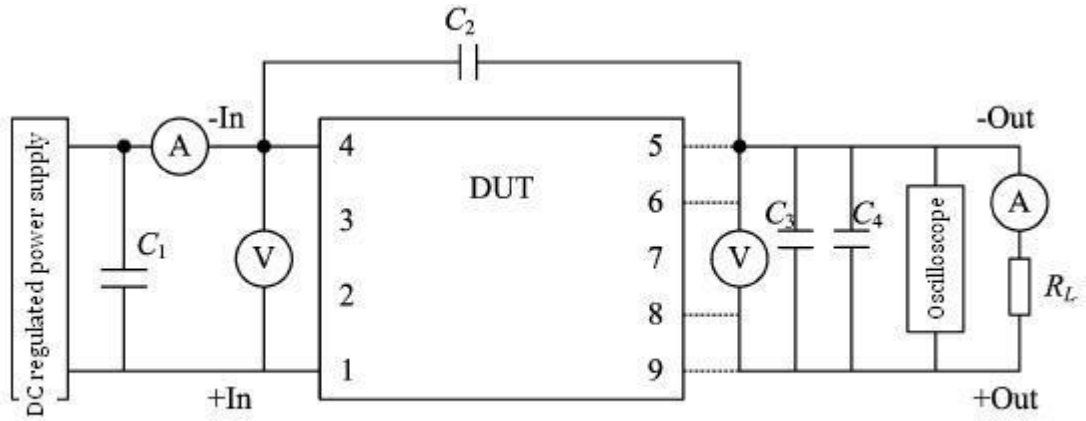

Fig 6 Electrical testing wiring diagram

10. Package Specifications

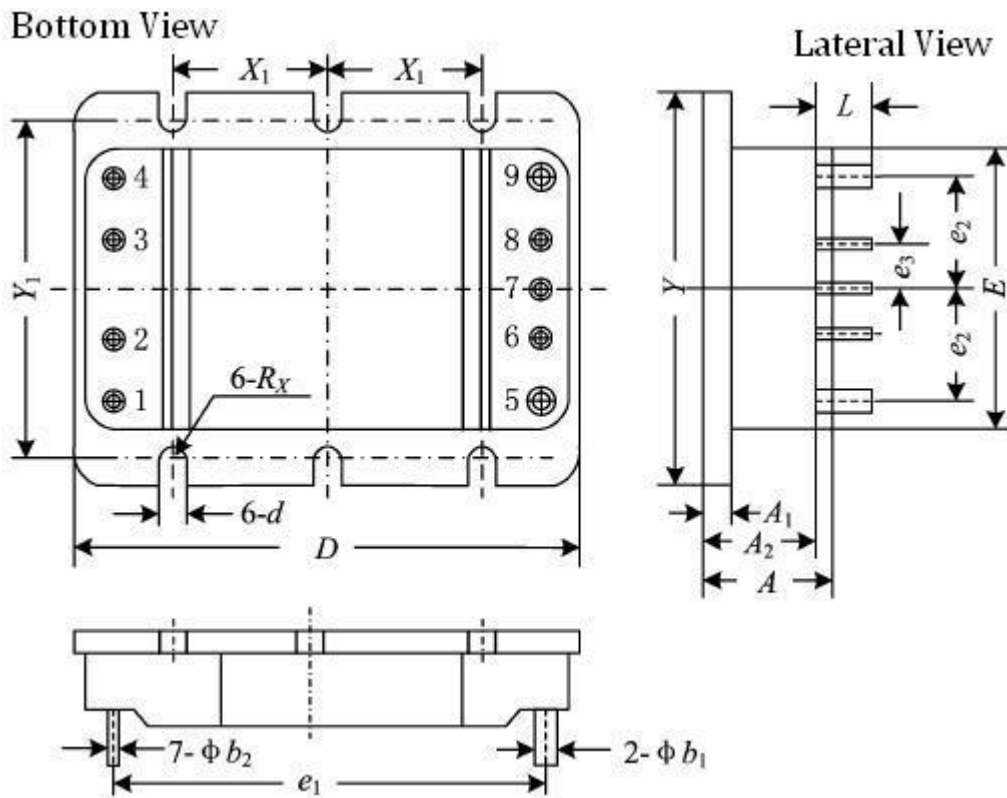

Fig 7 package outline drawing (upward view)

Form 5 Package Outline

Symbol	Data/mm		
	Min	Typical	Min
A	12.20	-	13.50
A ₁	2.80	-	3.30
A ₂	10.65	-	12.40
Φb1	3.68	-	3.94
Φb2	1.90	-	2.16
D	57.52	-	58.28
E	43.95	-	44.95
e2	-	17.78	-
e3	-	7.62	-
e1	-	48.26	-
L	4.58	-	-
X1	16.26	-	16.76
Y1	50.55	-	51.05
d	3.17	-	3.55
Y	55.65	-	56.15

11 Ordering Information

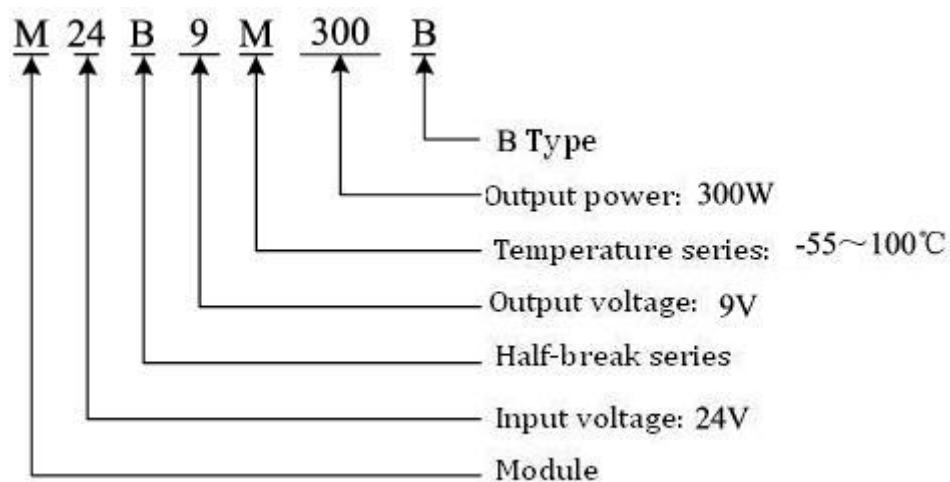

Fig 8 Ordering Information

Application Notes:

- ☆ The influence of external disturbance on the test accuracy should be avoided.
- ☆ The voltage detection point should be kept at the root of the pin of the testing product.

☆ Do not plug the product with electricity.

☆ Before power the testing product, you must confirm the polarity of the power supply to avoid damaging products by misconnection. At the same time, please ensure that the power supply voltage and load current does not exceed using limitation of the testing product.

☆ When using the shell temperature can not exceed the specified temperature, or to increase the use of heat sink.

☆ When ordering this device , the detailed electrical specifications shall be based on relevant standards.